



True to the Music

PRESENTER™

**MICROPHONE & LAPTOP
PRESENTATION MIXER**



Radial Engineering Ltd.

1588 Kebet Way, Port Coquitlam BC V3C 5M5

Tel: 604-942-1001 • Fax: 604-942-1010 • Email: info@radialeng.com

PRESENTER MICROPHONE & LAPTOP PRESENTATION MIXER

| | |
|------------------------------------|------------|
| Introduction..... | 1 |
| Features | 2-3 |
| Overview..... | 4 |
| Making Connections..... | 5-8 |
| Recording with the Presenter | 9 |
| Specifications | 10 |
| Block Diagram | 11 |
| Radial Limited Warranty | Back Cover |

Thank you for purchasing the Radial Presenter™, a microphone and laptop presentation mixer that allows you to easily provide high quality audio for any event, lecture, or presentation.

While the Presenter has been designed to be easy to use, we encourage you to read through this short manual to become familiar with the various features and how to use them. If you find yourself with unanswered questions, please visit our website at www.radialeng.com. This is where we post frequently asked questions and product updates. If you still require assistance, send us an email at info@radialeng.com and we will do our best to respond promptly.

FEATURES



- MIC LEVEL:** Gain control sets the microphone input level.
- LOW CUT:** 3-position switch rolls off excessive low frequencies.
- EQ:** Low and High controls allow you to adjust the tone of the microphone.
- AUDIO PROGRAM LEVEL:** Controls the level of the USB audio input and the 3.5mm input.
- 3.5mm PROGRAM INPUT:** Mini 1/8" TRS input allows you to playback audio from a smartphone or tablet.
- POWER INDICATOR:** Illuminates when the Presenter is receiving power via USB.

FEATURES

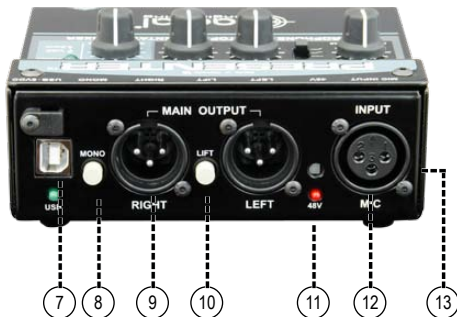

7. **USB:** Provides power for the Presenter and allows playback of high quality audio from a laptop.
8. **MONO:** Sums the left and right outputs to mono.
9. **MAIN OUTPUTS:** Balanced XLR line outputs connect directly to powered PA speakers.
10. **LIFT:** Ground lift switch disconnects ground on pin-1 at the XLR outputs to remove buzz and hum.
11. **48V:** Recessed switch engages phantom power for condenser microphones.
12. **MIC INPUT:** Balanced XLR input to connect a microphone.
13. **KENSINGTON SLOT:** Allows the Presenter to be secured with a Kensington Lock to prevent theft.

OVERVIEW

The Presenter combines a microphone preamp and a USB program input to create the ultimate interface for any presentation, from school lectures to corporate audio. An XLR mic input allows you to connect a podium microphone and provide it with phantom power. The mic signal can then be adjusted using three EQ controls: a high-pass filter rolls off excessive low end, and Low and High knobs allow you to tailor the frequency response. A program input level controls the volume of the USB input or the 3.5mm jack on the front of the unit, so you can connect the outputs of your laptop, smartphone, or tablet and blend it with the signal from the microphone. XLR outputs provide balanced feeds for a set of powered speakers, providing an all-in-one portable solution for any speaking engagement.

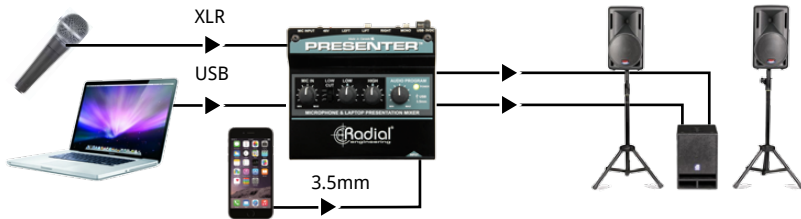

MAKING CONNECTIONS

Powering the Presenter

Before connecting the Presenter, ensure that your devices are turned down and powered off, to prevent plug-in transients from damaging sensitive speaker components such as tweeters.

The Presenter is powered via a USB cable, connected either to a laptop computer or a separate AC power adapter. Once connected to power, the LED on the top panel of the Presenter will illuminate and the device will be ready to use.



USB power adapter not included

The Main Outputs

The Presenter features two line-level XLR outputs to feed a set of powered speakers or the line inputs of a PA system. These are balanced, low impedance outputs that can be sent distances of up to 100m (300') without signal loss or noise. Connect to your sound system using standard XLR cables, then turn on your speakers and turn up the volume. Should you encounter buzz or hum caused by a ground loop, engage the LIFT switch on the rear of the Presenter to disconnect the pin-1 audio ground connection and help eliminate the noise. If you wish to have your audio playback in mono, or if you are only connecting to a single powered speaker, engage the MONO switch next to the USB input. With the mono switch engaged, the same signal will be present on both the left and right XLR outputs.

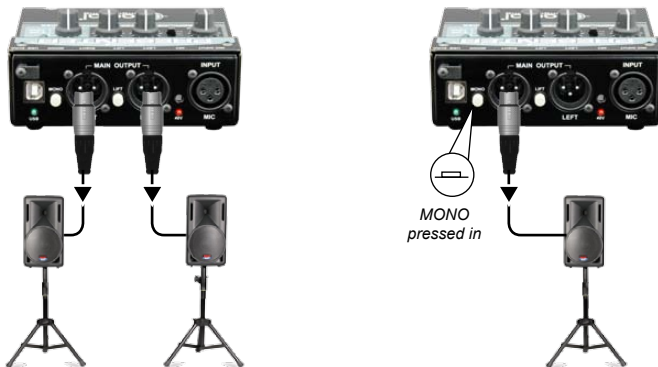

The Microphone Input & Tone Controls

The MIC INPUT on the Presenter allows you to connect to your microphone using a standard XLR cable. This input is compatible with handheld and podium mics, or the output of a wireless microphone receiver. If your microphone requires 48V phantom power to operate, simply engage the recessed 48V switch before turning up your levels – a red LED will illuminate on the back of the Presenter to let you know that phantom power is active. The MIC IN knob will set the overall output level of the microphone.

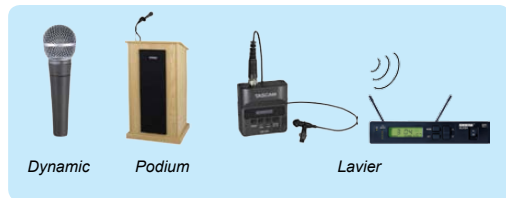

Three tone shaping controls are also provided to tailor the sound of the microphone to suit the environment or the timbre of the speaker. The LOW CUT switch allows you to engage a filter that eliminates excessive low frequencies: the middle setting on this three-position switch rolls off frequencies below 80Hz, while the lowest setting rolls off below 120Hz. The LOW and HIGH controls are shelving equalizers that allow you to boost or cut the low and high frequencies. Start with these controls at 12 o'clock and adjust to suit when speaking into the microphone and listening to the output of your speakers – the EQ settings can go a long way towards increasing the clarity of your voice in the room.



3.5mm Input

The input on the front of the Presenter allows you to easily connect a smartphone or tablet for audio playback through your sound system. Use a standard 3.5mm (1/8") TRS cable to connect your device to the Presenter, and slowly turn up the AUDIO PROGRAM level control until you've reached the desired playback volume. Note that when a cable is connected to the 3.5mm jack, this input will take priority over the USB input, and any audio being played back over the USB connection will be muted.



The USB Input

The USB input on the Presenter allows you to playback audio from a laptop computer, utilizing high quality digital converters that are capable of sample rates up to 96kHz. This makes the Presenter ideal for playing a music playlist at a wedding reception, or audio files within a PowerPoint® slideshow for a lecture.



TYPE A USB

Fits most laptops and computers



TYPE B USB

Used to connect to the Presenter

The Presenter is a plug and play device, with no drivers required to work with either a Mac or a PC. Once connected to your computer via USB, the Presenter will appear in the list of available devices in your system settings. When playing back audio from your computer, the AUDIO PROGRAM level control will set how much of the USB audio will feed the outputs of the Presenter. Test USB playback with the AUDIO PROGRAM turned down, then slowly turn it up until you reach an appropriate volume through the PA. Also ensure that you don't have a 3.5mm cable connected to the front input on the Presenter, as this will override the USB input and effectively mute the output from your computer.

Note: The Presenter's USB input is only designed to be used with laptop computers. To connect any mobile or iOS device to the Presenter such as a smartphone or tablet, use the 3.5mm input provided on the front of the unit.

Using the Presenter as a recording interface

The Presenter can also be used as an analog to digital recording interface when using the USB connection into a laptop computer. This allows you to record the microphone input for podcasts or to save the audio of a lecture to distribute to students afterward.

When using the Presenter to record a lecture or presentation, make sure to first set the microphone level to ensure that you're feeding an appropriate signal level to your recording software. Once this level is set, adjust the controls on your speakers until you reach the desired level in the room. Lastly, begin playback on your program material and slowly bring up that level to suit.

SPECIFICATIONS*

| | |
|--------------------------------|---|
| Audio Circuit Type: | Active preamplifier circuit with digital to analog input conversion |
| Frequency Response: | 20Hz to 20kHz |
| Noise Floor: | -84dBu |
| Dynamic Range: | +91dBu |
| Maximum Input: | +7dBu |
| Gain: | +52dBu |
| Intermodulation Distortion: | 0.003% @ 0dBu, 0.01% @ -10dBu, 0.03% @ -20dBu |
| Total Harmonic Distortion: | 0.004% @ 20Hz, 0.004% @ 1kHz, 0.004% @ 10kHz |
| Phase Deviation: | -28° @ 20Hz, -1° @ 1kHz, +2° @ 10kHz |
| Input Impedance: | 10kΩ |
| Output Impedance - XLR Output: | 2.74kΩ |
| Insertion Loss: | 0dB |
| Power: | 5V USB |
| Construction: | 16-gauge steel chassis & outer shell |
| Warranty: | Radial 3-year, transferable |

* Subject to change without notice.

BLOCK DIAGRAM*

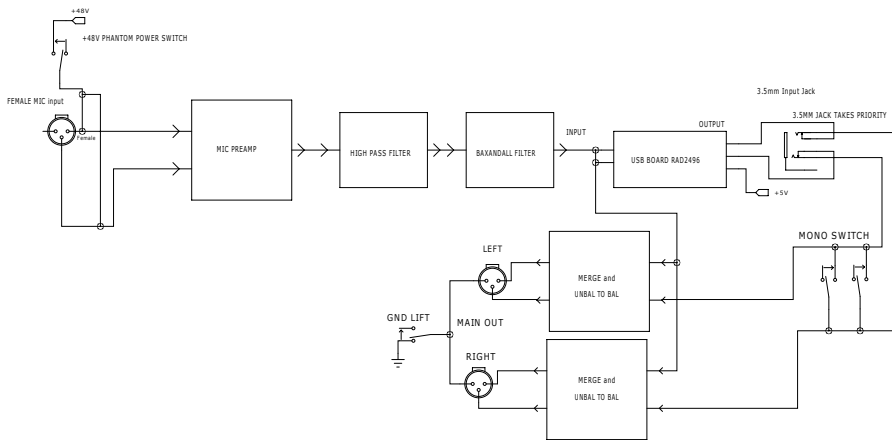

* Subject to change without notice.

RADIAL ENGINEERING 3 YEAR TRANSFERABLE WARRANTY

RADIAL ENGINEERING LTD. ("Radial") warrants this product to be free from defects in material and workmanship and will remedy any such defects free of charge according to the terms of this warranty. Radial will repair or replace (at its option) any defective component(s) of this product (excluding finish and wear and tear on components under normal use) for a period of three (3) years from the original date of purchase. In the event that a particular product is no longer available, Radial reserves the right to replace the product with a similar product of equal or greater value. In the unlikely event that a defect is uncovered, please call 604-942-1001 or email service@radialeng.com to obtain an RA number (Return Authorization number) before the 3 year warranty period expires. The product must be returned prepaid in the original shipping container (or equivalent) to Radial or to an authorized Radial repair center and you must assume the risk of loss or damage. A copy of the original invoice showing date of purchase and the dealer name must accompany any request for work to be performed under this limited and transferable warranty. This warranty shall not apply if the product has been damaged due to abuse, misuse, misapplication, accident or as a result of service or modification by any other than an authorized Radial repair center.

THERE ARE NO EXPRESSED WARRANTIES OTHER THAN THOSE ON THE FACE HEREOF AND DESCRIBED ABOVE. NO WARRANTIES WHETHER EXPRESSED OR IMPLIED, INCLUDING BUT NOT LIMITED TO, ANY IMPLIED WARRANTIES OF MERCHANTABILITY OR FITNESS FOR A PARTICULAR PURPOSE SHALL EXTEND BEYOND THE RESPECTIVE WARRANTY PERIOD DESCRIBED ABOVE OF THREE YEARS. RADIAL SHALL NOT BE RESPONSIBLE OR LIABLE FOR ANY SPECIAL, INCIDENTAL OR CONSEQUENTIAL DAMAGES OR LOSS ARISING FROM THE USE OF THIS PRODUCT. THIS WARRANTY GIVES YOU SPECIFIC LEGAL RIGHTS, AND YOU MAY ALSO HAVE OTHER RIGHTS, WHICH MAY VARY DEPENDING ON WHERE YOU LIVE AND WHERE THE PRODUCT WAS PURCHASED.



www.radialeng.com

Radial Engineering Ltd.

1588 Kebet Way, Port Coquitlam BC V3C 5M5

Tel: 604-942-1001 • Fax: 604-942-1010 • Email: info@radialeng.com



Presenter™ User Guide - Part #: R870 1039 00 / 01-2018 Copyright © 2018, all rights reserved.

Appearance and specifications subject to change without notice.

Made in Canada 